

## Overview

Walchem and Iwaki have created a unique partnership with over 100 years of combined pump experience in an array of different markets. This talent has led to the design of the most innovative and comprehensive metering pump product line in the world, the E-Class Metering Pumps.

E-Class features four great series: EZ, EW, EK and EHE. The variety of pumps within the E-Class will fit any water treatment, wastewater, agriculture, water conditioning, car wash or other industrial feed application.



## EZ Series

### E-Class Metering Pumps

#### Summary of Benefits

- **High Speed Operation**  
Up to 360 strokes-per-minute results in high resolution chemical feed, elimination of slug-feed effects.
- **Modular Design**  
The liquid end, drive and electronics are modular, enabling economical repair or replacement of parts. The control module can easily be mounted in a remote location.
- **Double Ball Check Valves**  
Precision valve guide assemblies prevent loss of prime and ensure easy self-priming of 100 cps viscosity solutions with a 5ft. suction lift.
- **Optional Automatic Air Vent Valve**  
Eliminates loss of prime when pumping liquids that de-gas easily.
- **Long Lasting Diaphragm**  
PTFE laminate over EPDM is molded onto a solid core. A retainer plate is provided to minimize flow rate changes as pressure varies.

**W A L C H E M**

# EZ Series

The EZ Series electronic metering pumps with microprocessor control offer precise chemical injection at a low cost.

EZ pumps have outputs to 6.3 GPH and pressure capabilities to 150 PSI. The compact size and simple control make it ideal for OEM applications.

Effective, reliable performance is achieved through sophisticated engineering. Designed with a turndown ratio of 360:1, the EZ is an exceptional value.

## Digital Speed Control

The EZ is simple to operate with three pushbutton keys. The 360:1 turndown ratio provides unmatched versatility.

## Timer Control Module Option

The EZ-Timer module integrates Walchem's EZB technology with a versatile programmable timer. Timed feed control can be programmed in daily or weekly cycles. The weekly schedules can be programmed in either 1 or 2-week cycles with a daily on-time. The daily timer can be set for multiple daily on-times. On-times are set in minutes (0-999).

The EZ-Timer pump is a simple and effective way to automate additions in small systems. With capacities up to 3.2 GPH and pressure ratings up to 150 psi, the EZ-Timer pump is perfect for many applications, including accurate, consistent addition of biocides into your cooling tower system.



Digital speed control



Timer control module option



Simply stated - the EZ packs all of the 360spm performance of the bigger pumps into the compact chassis of the industry's easiest pump to operate. The EZ is the best on/off pump on the market. Built to prime, hold prime and to last, the EZ Series metering pump offers precise chemical injection at an economical cost. Features include double ball check valves, long lasting diaphragm and an optional automatic air vent valve.

**2-Year Warranty**  
"Bumper-to-Bumper" On All  
E-Class Pumps  
- Including Worn Parts

## Electrical

EZ	EZB	EZC
50/60 Hz, single phase	20 Watt avg.	22 Watt avg.
115 VAC ± 10%	0.8 Amp max	1.2 Amp max.
230 VAC ± 10%	0.4 Amp max.	0.6 Amp max

## Safety Performance

The EZ Series metering pumps are tested by Intertek to UL and CSA standards. They have also been certified by NSF International to ANSI/NSF Std. 61.



## Shipping Weight (approximate)

6 lbs. (2.7 kg)	8 lbs. (3.6 kg)
-----------------	-----------------

## Operating Conditions

Ambient temperature	32°F to 122°F (0°C to 50°C)
Relative humidity	30% to 90% non-condensing
Liquid temperature	32° to 104°F (0 to 40°C) for PVC based liquid ends 32° to 140°F (0 to 60°C) for PP & PVDF based liquid ends Below 32°F (0°C), pump is limited to 70% of max. pressure. Liquid cannot freeze.

## Dimensions

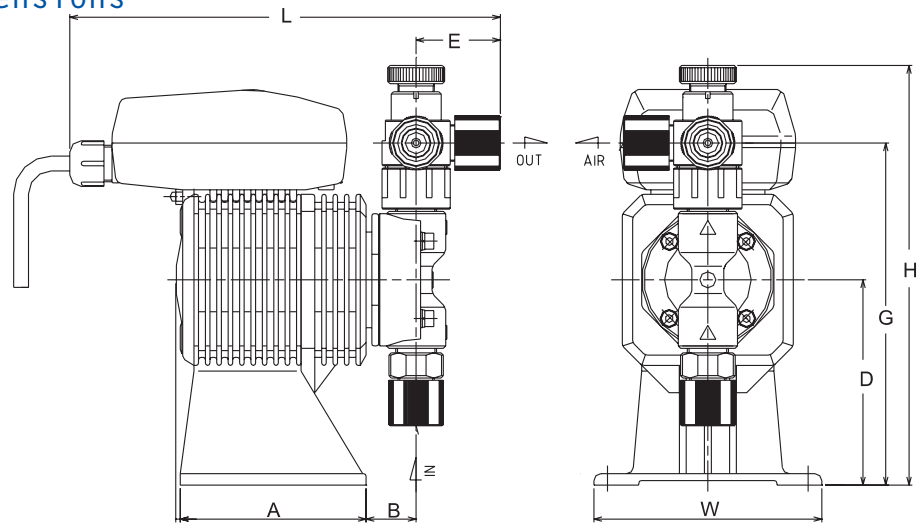

## Mounting Dimensions (inches)

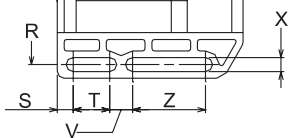

Model	R	S	T	X	V	Z
EZB Series	3.46	0.28	0.63	0.24	0.39	1.26
EZC Series	3.94	0.59	1.18	0.28	0.59	1.18

Approximate dimensions for larger size pump

Model	A	B	E	D	G	H	L	W
EZB	3.2	1.0	1.5 <sup>1</sup>	3.5	6.8 <sup>2</sup>	8.0	7.5	3.9 <sup>3</sup>
EZC	4.1	1.1	1.5 <sup>1</sup>	3.9	7.1 <sup>2</sup>	8.4	8.2	4.6 <sup>3</sup>

Notes for EW10, 15, 20:

1. Addition of a Multifunction valve increases overall length by 0.37". Addition of an Auto Air Vent Valve increases overall length by 1.59"
2. Addition of a Multifunction Valve increases discharge height by 0.22". No change for the Auto Air Vent Valve.
3. Addition of a Multifunction Valve increases overall liquid end height by 1.16". No change for the Auto Air Vent Valve.

## Standard Materials of Construction

<b>CE</b>	Alumina ceramic	<b>PE</b>	Polyethylene
<b>EPDM</b>	Ethylene propylene diene monomer	<b>PTFE</b>	Polytetrafluoroethylene
<b>FKM</b>	Fluoroelastomer	<b>PVC</b>	Polyvinylchloride (translucent)
<b>GFRPP</b>	Glass fiber reinforced polypropylene	<b>PVDF</b>	Polyvinylidene fluoride

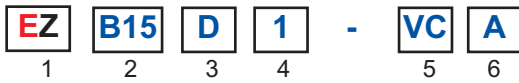

## 1 PUMP SERIES

**EZ** Electronic metering pump with manual speed control (adjustable to 360 strokes per minute)

## 2 CAPACITY/PRESSURE RATING

Size	Max. Output Capacity		Max. Output per Stroke	Max. Pressure <sup>1</sup>		Connection Size (in)
	GPH	ml/min	ml	PSI	MPa	Tubing O.D.
B10	0.6	38	0.11	150	1.0	3/8
B15	1.0	65	0.18	105	0.7	3/8
B20	1.5	95	0.26	60	0.4	3/8
B30	3.2	200	0.56	30	0.2	1/2
C15	1.3	80	0.22	150	1.0	3/8
C20	2.0	130	0.36	105	0.7	3/8
C30	4.3	270	0.75	50	0.35	1/2
C35	6.3	400	1.17	30	0.2	1/2

<sup>1</sup> Auto Air vent valve reduces maximum pressure approx. 35PSI (0.2 mPa)

## 3 CONTROL MODULE

**D** = Manual speed adjustment from 1-360 spm

**T** = Timer control module (available on 115V EZB pumps only)

## 4 VOLTAGE

**1** = 115VAC, 50/60 Hz

**2** = 230VAC, 50/60 Hz

## 5 LIQUID END

Liquid End	Pump Head & Fittings	Diaphragm	Valve Balls	Valve Seat	Valve Seals	Gasket	Tubing
PC	GFRPP	PTFE BONDED TO EPDM	CE	FKM	FKM	PTFE	PE
PE	GFRPP		CE	EPDM	EPDM		
VC	PVC		CE	FKM	FKM		
VE	PVC		CE	EPDM	EPDM		
FC	PVDF		CE	PCTFE	PTFE		
TC	PVDF		CE	FKM	FKM		

## 6 OPTIONS

**BLANK** = Standard manual air vent valve included, except with liquid end code -FC.

**A** = Automatic air vent valve installed. For VC liquid ends on B10, B15, C15 & C20 size pumps only. Pressure rating is reduced by 35 psi with valve installed.

**M** = Multi-function back pressure/anti-syphon valve installed. For PC, PE, VC and VE liquid ends on 10, 15 and 20 size pumps only. Not available with the AAVV feature.

All pumps include a manual air vent valve with the exception of FC liquid ends. All pumps include one foot valve, one injection valve, 20 feet of polyethylene tubing and one ceramic weight.



WEBMASTER GENERAL INDUSTRIAL CONTROLLER



WEBMASTER BOILER CONTROLLER



METERING PUMPS AND ACCESSORIES



WEBALERT REMOTE MONITORING & DATALOGGING

Walchem designs and manufactures an integrated line of analytical control, sensing and metering equipment.

Our in-house engineering is driven by quality, technology and innovation.

For more information on the entire Walchem product line, visit : [www.walchem.com](http://www.walchem.com)



180165.G 4/24/07