

# Instructions

---

## Dispenser Networking Software for Windows

### Overview

This program replaces previous laundry dispenser networking software, to be compatible with newer dispenser ROM versions. See the About box in the Help menu on the networking software desktop for compatibility issues. The program allows you to connect all of the dispensers at a single account site into one network and communicate with the network from a local or remote PC.

### PC Requirements

- Windows 3.x, Windows '95, Windows '98 or Windows NT.
- 486 or later processor.
- At least 8 megabytes of RAM.
- At least 15 megabytes of available hard disk space to install this software.
- A 3-1/2" floppy disk drive from which to install the program.
- For local connections, an available serial port.
- For remote connections, a modem.

### Conversion of Information

The communication protocol for information coming from the dispenser network is RS-485. This must be converted to RS-232 before connecting to the PC's commport. There are two ways to do this: with the B&B Model 485COSR Converter (used with older networking software) or with the Protocol Converter/Port Selector. The advantage to using the Protocol Converter/Port Selector is that it allows a modem to be connected to the network so that both a local PC and a remote (via modem) PC can alternately supervise the network. The Protocol Converter/Port Selector automatically switches between the local PC and modem (remote PC), since only one PC can supervise the network at one time.

### Hardware Requirements

The following hardware is required to connect the dispensers to form the dispenser network, and connect the dispenser network to a remote or local PC.

- Two-conductor, 22-gauge (CSA mm2) twisted-pair cable to link the dispensers in a daisy chain. This cable runs between all of the dispensers, connecting at each on the Main or Model 100 PCB's RS-485 two- or three-conductor Phoenix Connector or the dispenser's terminal block. Shielding is not required, except in extreme applications.

### If Using the RS485 Converter

- An RS-485 cable is used to connect the Converter to the dispenser network. It may be necessary to extend this cable to cover the distance between the dispensers (probably located in the wash aisle) and the PC (probably located in an office) using 22-gauge (CSA mm2) cable.
- The RS-485 to RS-232 Converter B&B Model 485COSR and power supply. This may be a direct connection but a generic 25- to 9-pin adapter and/or a short cable may be required or desired depending on the PC configuration and access to the comm ports. The RS485 to RS232 Converter should be as close to the PC as possible

### If Using the Protocol Converter/Port Selector

- The cable connecting the dispenser network to the Protocol Converter/Port Selector is two-conductor, 22 gauge (CSA mm2) twisted pair cable. The Protocol Converter/Port Selector should be located near the PC.
- The Protocol Converter/Port Selector and power supply.
- Serial cable with either a 9-pin or a 25-pin female D connector for the PC side and a 25-pin male D connector for the Protocol Converter/Port Selector side.

### Connect the Dispenser Network

1. The RS-485 connection provides the basis for communication between the dispensers and the PC. The ILS is manufactured with the RS-485 connection wired directly from J10 on the Model 100 PCB to a 5-pin DIN connector on the front panel. If this is the case, remove this connection before wiring the dispensers together. Other dispensers have the Model 100 PCB's RS-485 port available at a terminal block. See **Figure 1** to locate your dispenser's network connection. **Figure 1** shows a dispenser network with four styles of dispenser. It also illustrates the RS-485 to RS-232 conversion using both the B & B Converter and the Protocol Converter/Port Selector.

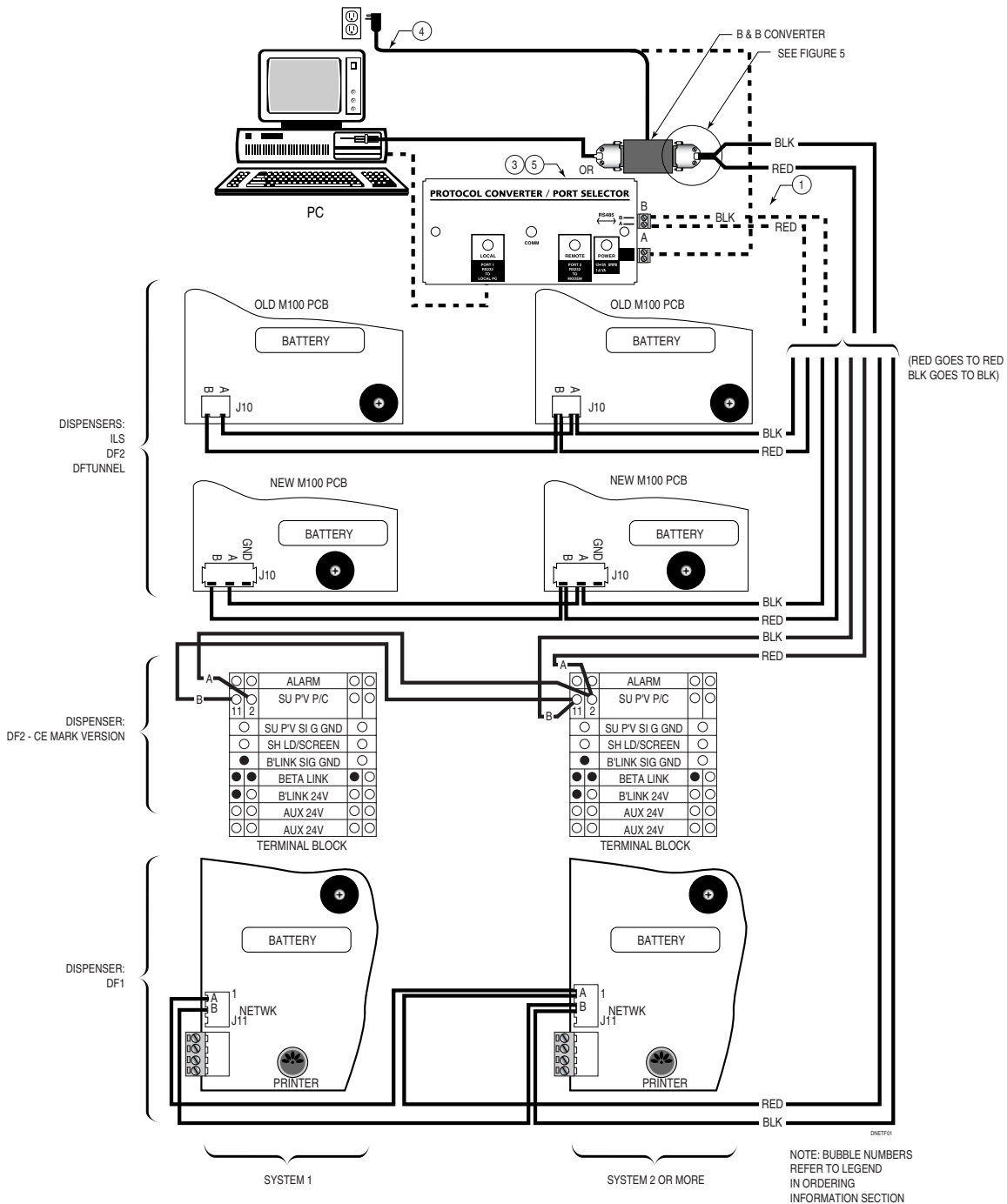

Figure 1. Dispenser Network Connections

- Disconnect power to all of the dispensers and locate their network connections. Remember that these connections are polarized. Connect A of one unit to A of the next unit and B to B. (The polarity markings are visible when the connector portion is disconnected from the PCB). Disregard +/- designation.



The various dispensers are daisy-chained in parallel (see Figure 3). The order of connection is not important, nor is the point at which the computer connection is made.

You can also connect different model dispensers into a network, as shown in Figure 2. Take special note of polarity connections between units (see Figure 3).

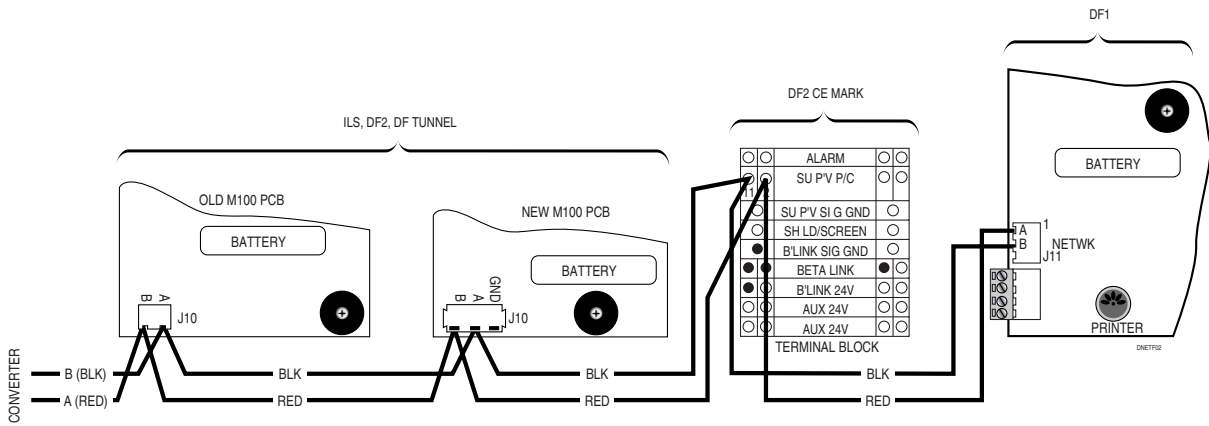

Figure 2. Multiple Dispenser Models in a Dispenser Network

UNIT OR PCB	CONVERTER TERMINAL A (RED)	CONVERTER TERMINAL B (BLACK)
Old Model 100	B	A
New Model 100	B	A
DF2-CE	2	11
DF1	A	B

Figure 3. Connection Polarities

You may need to lengthen your RS-485 cable to accommodate the new network. Use a 22-gauge (CSA mm<sup>2</sup>) twisted pair cable. Refer to **Figure 5** for exact wiring details.

3. You will now need to change the network address of each dispenser to a unique, nonzero number. Do this at the dispenser's front panel. Go to program mode (refer to the dispenser's installation and operation manual). Scroll to the Account ID menu and change the network ID. It is recommended that the dispensers be addressed sequentially beginning with 01, but it is not necessary that the PC be directly connected to the dispenser with Network ID 01. The maximum number of network ID's is 30.

## Connect the Dispenser Network to a Local PC Using Converter

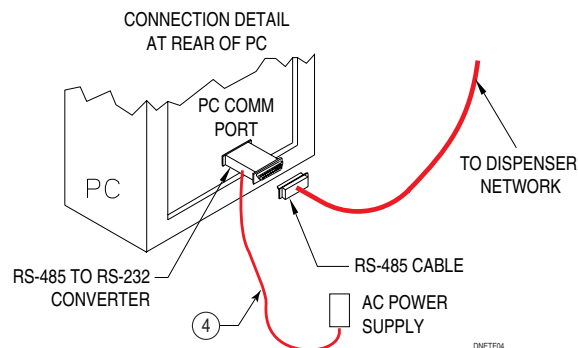

Figure 4. Network to Local PC Connection Using Converter

1. Refer to **Figure 4**. Connect the 25-pin D connector end of the cable to the RS-485 side of the Converter. You may need to lengthen your RS-485 cable to accommodate the new network. Use a 22-gauge (CSA mm<sup>2</sup>) twisted pair cable. Refer to **Figure 5** for exact wiring details.
2. Plug in the power supply for the Converter.

3. Connect the RS-232 side of the Converter directly into an available serial comm port on your PC. You may need to use a 9-pin to 25-pin serial cable if your PC has a 9-pin serial port. (Available at any electronics store.)

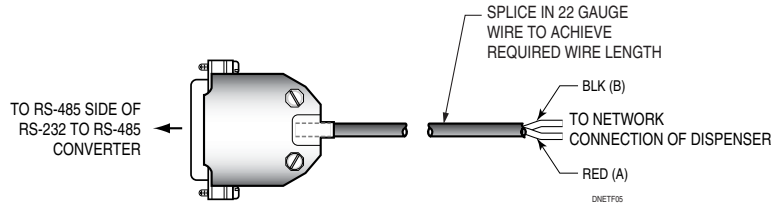

Figure 5. RS-485 Cable

## Connect Dispenser Network to a Remote PC Using Converter and Modem

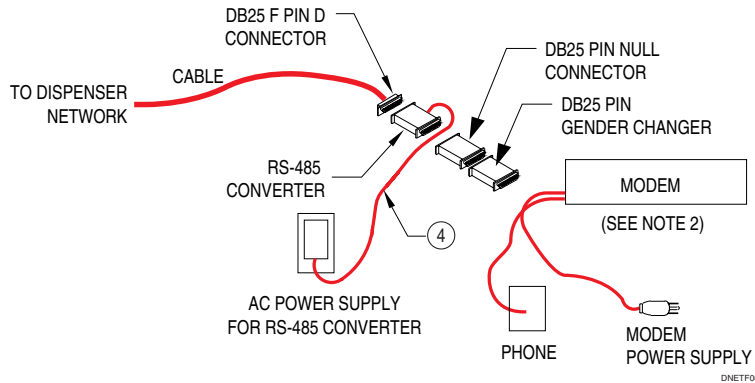

Figure 6. Network to Remote PC Connection Using Converter and Modem

1. Refer to **Figure 6**. Create the dispenser network as explained above, but rather than connecting the RS-232 side of the RS-485 converter to the PC's serial port, connect it to a 25-pin Null Modem and then to a 25-pin male-to-male gender changer (both items are available at any electronics store).
2. Connect the free end of the gender changer to the serial port of the US Robotics external modem (Classic, Classic V or Sportster models). Note that the modem must have a bank of 8 DIP switches.
3. Set the modem's DIP switches 1, 3, 7, and 8 down and the rest up.
4. Plug in the power for the modem and connect it to a phone jack.
5. Power on the modem. Communication between the dispenser and modem will be at 9600 baud, regardless of the modem speed.

## Connect Dispenser Network to a Local PC with Protocol Converter/Port Selector

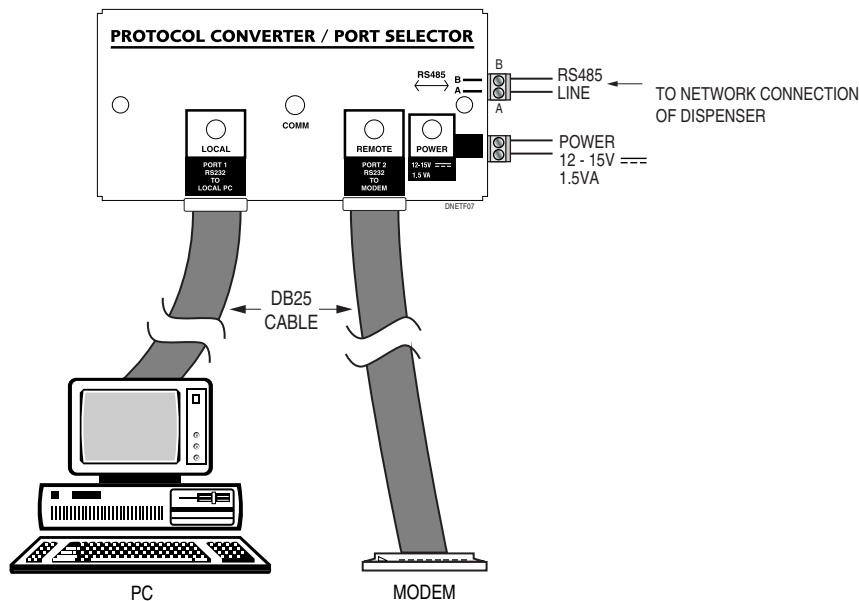



Figure 7. Network to Local PC Connection Using Modem and Protocol Converter/Port Selector

1. See Figure 7. Run 2-conductor cable from the dispenser network to the Protocol Converter/Port Selector.
2. Connect the 485 lines to the Protocol Converter/Port Selector input lines A/B.
3. Power the Protocol Converter/Port Selector using a 12-15  power supply available at any electronic store or available to order (see **Ordering Information**). If you order our power supply, you will need to cut off the existing connector, strip the wires and attach them to the Phoenix plug. Polarity of the power supply is inconsequential.
4. Connect the female DB-25 LOCAL output of the Protocol Converter/Port Selector to the PC's serial port. You will need a standard 9- or 25-pin RS-232 serial cable to make this connection.

## Connect Dispenser Network to a Local and Remote PC with Protocol Converter/Port Selector and Modem

1. Do steps 1 - 4 above.
2. Refer to **Figure 7** and connect the male DB-25 remote output of the Protocol Converter/Port Selector to a US Robotics modem (Classic, Classic V or Sportster model). Use a 25- to 25-pin RS-232 serial cable to make this connection.
3. Set DIP switches 1, 3, 7 and 8 down and the rest up.
4. Plug in the power for the modem and connect it to a phone jack.



*When a remote PC connects, it automatically becomes the RS-485 network supervisor; when it disconnects, the local PC regains the supervisor role.*

## Install the Software at the PC

1. Insert the first of the four floppy install disks in the floppy disk drive of your PC.
2. For Windows 3.x, from the Program Manager, choose **File | Run**. Type **A:\Setup** and click **OK**. Note that if you inserted the disk into a drive other than A, use that drive's letter. You do not need to do step 4.
3. For Windows '95, Windows '98 and Windows NT, from the **Start** menu, choose **Settings | Control Panel**. Double click on the **Add/Remove Programs** icon. Windows should automatically find setup.exe on the floppy drive. Click **OK** to launch the setup program.
4. Follow the on-screen directions to install the software. Make sure you enter the serial number printed on your install disk label accurately. When you complete the setup, remove the last disk. Store all the install disks in a safe location.
5. The program is password protected. To log on after installation, select Default Supervisor from the dropdown list as your user name, type zaybx as the password and click O.K. For access protection, keep this password private.
6. See the online help for information on how to use the program. You should set your personal log on name, password and access level during your first session and thereafter use that name and password to log on. To set your password, choose Edit Passwords from the file menu.



*If you have difficulty installing the software, contact your local IT group.*

## Ordering Information

Seq No.	Part	Item No.
1	Two-conductor, 22-gauge (CSA mm <sup>2</sup> ) twisted-pair cable	041747
3	Protocol Converter/Port Selector (with power supply, North American version)	097906
4	Power Supply for North American Version Protocol Converter/Port Selector or Converter	055697
5	Protocol Converter/Port Selector (without power supply, European version)	097962



### Western Hemisphere & Pacific Rim DiverseyLever Equipment, Inc.

P.O. Box 265  
5455 Moose Lodge Road  
Cambridge, MD 21613 U.S.A.  
Tel +1 - 410 - 228 - 5111  
Fax +1 - 410 - 228 - 5664  
Tel +1 - 410 - 228 - 1292 (Tech Support)

<http://intranet.diverseylever.unilever.com>

### Europe, Africa & Middle East DiverseyLever Equipment, Ltd

4 Finway Dallow Road  
Luton LU1 1TR  
United Kingdom  
Tel +44 - 1582 - 702191  
Fax +44 - 1582 - 702173  
Tel +44 - 1623 - 728058 (Tech Support)